

**Magnetic Tape Storage
and Handling
A Guide for Libraries and Archives**

June 1995

The Commission on Preservation and Access is a private, nonprofit organization acting on behalf of the nation's libraries, archives, and universities to develop and encourage collaborative strategies for preserving and providing access to the accumulated human record.

Additional copies are available for \$10.00 from the Commission on Preservation and Access, 1400 16th St., NW, Ste. 740, Washington, DC 20036-2217. Orders must be prepaid, with checks in U.S. funds made payable to "The Commission on Preservation and Access."

This paper has been submitted to the ERIC Clearinghouse on Information Resources.

The paper in this publication meets the minimum requirements of the American National Standard for Information Sciences-Permanence of Paper for Printed Library Materials ANSI Z39.48-1992.

ISBN 1-887334-40-8

No part of this publication may be reproduced or transcribed in any form without permission of the publisher. Requests for reproduction for noncommercial purposes, including educational advancement, private study, or research will be granted. Full credit must be given to the author, the Commission on Preservation and Access, and the National Media Laboratory. Sale or use for profit of any part of this document is prohibited by law.

Magnetic Tape Storage and Handling

A Guide for Libraries and Archives

**by Dr. John W. C. Van Bogart
Principal Investigator, Media Stability Studies
National Media Laboratory**

**Published by
The Commission on Preservation and Access
1400 16th Street, NW, Suite 740
Washington, DC 20036-2217
and
National Media Laboratory
Building 235-1N-17
St. Paul, MN 55144-1000**

This report is a joint project of the Commission on Preservation and Access and the National Media Laboratory, developed within the Commission's Preservation Science Research initiative. The initiative encourages new techniques and technologies to manage chemical deterioration in library and archival collections and to extend their useful life.

The National Media Lab (NML) is an industry resource supporting the U.S. Government in the evaluation, development and deployment of advance storage media and systems. The NML endeavors to provide a broad perspective of current progress in storage issues, both from a commercial and government perspective.

The NML accomplishes its mission by acting:

- As a **CONSULTANT** to the U.S. Government, specializing in data storage and access requirements, assessing evolving technologies, determining applicability of currently available technologies to recording programs, and influencing commercial recording systems standards to accommodate Government requirements.
- As a **RESEARCH AND DEVELOPMENT FACILITY** which includes technology assessment and evaluation capabilities, measurements and testing laboratories, and prototype product development capabilities. This research facility is distributed across industry, university and Government laboratories.
- As a **TECHNICAL SERVICE** organization, providing user support at operational sites, field monitoring, rapid crisis response, and the transfer of technology and information.

- As an ADMINISTRATIVE AGENT in programs which require both broadly-based industrial and academic resources and coordination across Government/industry boundaries.

More information about the NML and its accomplishments is available on the Internet via the World Wide Web. You can access the NML Home Page at the following URL: <http://www.nml.org>

Table of Contents

Preface	vi
Author's Acknowledgments	vi
1. Introduction	1
1.1 Magnetic Media Compared to Paper and Film	1
1.2 The Scope of the Report	1
2. What Can Go Wrong with Magnetic Media?	2
Figure 1. Diagram of a Tape Reel	3
Figure 2. Cross Section of a Magnetic Tape	4
2.1 Binder Degradation	4
Lubricant Loss	5
2.2 Magnetic Particle Instabilities	6
2.3 Substrate Deformation	8
2.4 Format Issues	9
Helical versus Longitudinal Scan Recording	9
Figure 3. Helical Scan Recording	10
Figure 4. Types of Mistracking for Helical Scan Recording	11
Figure 5. Longitudinal Recording	12
Analog versus Digital Storage	12
2.5 Magnetic Tape Recorders	13
3. Preventing Information Loss: Multiple Tape Copies	14
4. Life Expectancy: How Long Will Magnetic Media Last?	14
4.1 Tape Costs and Longevity	15
4.2 Practical Life Expectancies	15
5. How Can You Prevent Magnetic Tape from Degrading Prematurely?	16
5.1 Care and Handling	17
Frequent Access	17
Transportation of Magnetic Tape	18
5.2 Storage Conditions and Standards	18
Temperature and Relative Humidity	19
Figure 6. Temperature and Humidity Conditions and Risk of Hydrolysis	20
Variations in Temperature and Humidity	20
Figure 7. Bad Tape Wind Examples	21
Dust and Debris	21
Figure 8. Size of Tape Debris Relative to the Tape/Head Spacing	22
Corrosive Gases	22
Storage Recommendations	23
Table 1. Current Recommendations for Magnetic Tape Storage	23

Table 2. Key Features of Access and Archival Storage of Magnetic Tape	24
Removal of Magnetic Tapes from Archival Storage	25
Table 3. Acclimation Times for Magnetic Media Removed from Archival Storage	26
5.3 Refreshing of Tapes	26
Appendix	28
Ampex Guide to the Care and Handling of Magnetic Tape	28
Recommended practices	28
Figure 9. Tape Debris	29
Tape handling	30
Rotary Head Recorders	32
Estimation of Magnetic Tape Life Expectancies (LEs)	34
Figure 10. Life Expectancies for a Hi Grade VHS Tape	34
Further Reading	35
Resources for Transfer and Restoration of Video and Audio Tape	36
Glossary	37

Preface

This report from the National Media Laboratory (NML) helps clarify long-term storage requirements for magnetic media. The information is derived from the industry's accumulated knowledge base, plus media stability studies and operations support activities conducted by the NML for the U. S. Government advanced data recording community. Clearly, the purpose and scope of long-term magnetic media storage issues for libraries and archives are different from those of many Government operations, but the basics remain the same.

The report focuses on how to properly store and care for magnetic media to maximize their life expectancies. However, it provides more than a how-to guide. The author includes technical explanations for the rationale behind recommended procedures, written specifically for librarians, historians, records managers, archivists, and others who do not have a significant background in recording technology. In addition, the report is useful for decision-making and cost-benefit analyses for managers and administrators who have responsibility for the long-term preservation of information stored on magnetic media.

Author's Acknowledgments

The author wishes to thank Devora Molitor, Peg Wetzel, Chris Ward, and Jim Druzik for their discerning comments, notable suggestions, and assistance in preparing this manuscript.

1. Introduction

The use of magnetic media to record and store numeric and textual information, sound, motion, and still images has presented librarians and archivists with opportunities and challenges. On the one hand, magnetic media increase the kinds of artifacts and events we can capture and store. On the other hand, their special long-term storage needs are different from traditional library materials, confusing to those in charge of their care, and demanding of resources not always available to libraries and archives.

Audio and video collections require specific care and handling to ensure that the recorded information will be preserved. Special storage environments may be required if the recorded information is to be preserved for longer than ten years. For information that must be preserved indefinitely, periodic transcription from old media to new media will be necessary, not only because the media are unstable, but because the recording technology will become obsolete.

1.1 Magnetic Media Compared to Paper and Film

As an information storage medium, magnetic tape is not as stable as film or paper. Properly cared for, film and nonacidic paper can last for centuries, whereas magnetic tape will only last a few decades. Use of magnetic media for storage is further confounded by the prevalence of several formats (e.g., U-matic, VHS, S-VHS, 8mm, and BetaCam for video), media types (iron oxide, chromium dioxide, barium ferrite, metal particulate, and metal evaporated), and by rapid advances in media technology. On the other hand, books have virtually maintained the same format for centuries, have almost exclusively used ink on paper as the information storage medium, and require no special technology to access the recorded information. Likewise, newer microfilm, microfiche, and movie film are known for their stability when kept in proper environments, and viewing formats have not changed significantly over the years. (The breakdown of acetate backing that plagues older film materials is discussed in Section 2.3: Substrate Deformation.) This report will compare care and handling procedures for tapes with procedures for paper and film whenever possible.

1.2 The Scope of the Report

As noted previously, this report is concerned with the proper care and handling of tapes to prevent information loss. Tape recording technology consists of two independent components — the magnetic tape and the recorder. Neither component is designed to last forever. Information recorded on a tape can be lost because of chemical degradation of the tape. However, access to information on a tape can also be lost because the format has become obsolete and a working recorder cannot be located. This document concentrates on preservation of the tape and mentions recorders only when needed to understand the safekeeping of tape. Care, maintenance, and preservation of recorders is beyond the scope of this report.

Likewise, the subject of disaster recovery is beyond the scope of this document. Recovery from a collection-wide disaster is best accomplished with the assistance of an expert in tape degradation, who can examine the whole collection and recommend a recovery procedure that may require special equipment. A few contacts for diagnosing and treating deteriorating tape collections are provided at the end of this document.

The handling practices discussed in this document are applicable to all audio and videotape collections—those accessed daily and those stored in an archive. If a particular recommendation is appropriate for only one type of storage, it will be indicated as such. Otherwise, it can be assumed that the recommendations herein apply to both types of tape collections — those accessed daily and those archived for preservation.

In this report, the audio or video program recorded on the tape is referred to as information. For example, the information recorded on an audio tape could be a sound studio recording, a concert performance, radio news broadcasts, a college lecture, or songbird calls. The information recorded on a videotape could be a TV program, a movie, a child's recital, a videotaped interview, an artist's original work, or a surveillance camera record.

To help understand some of the terminology associated with the magnetic recording field, a Glossary is provided. Words included in the Glossary appear in italics the first time they are referenced.

2. What Can Go Wrong with Magnetic Media?

Magnetic tape consists of a thin layer capable of recording a magnetic signal supported by a thicker film backing. The magnetic layer, or top coat, consists of a magnetic pigment suspended within a polymer binder. As its name implies, the binder holds the magnetic particles together and to the tape backing. The structure of the top coat of a magnetic tape is similar to the structure of Jell-O that contains fruit — the pigment (fruit) is suspended in and held together by the binder (Jell-O). The top coat, or magnetic layer, is responsible for recording and storing the magnetic signals written to it.

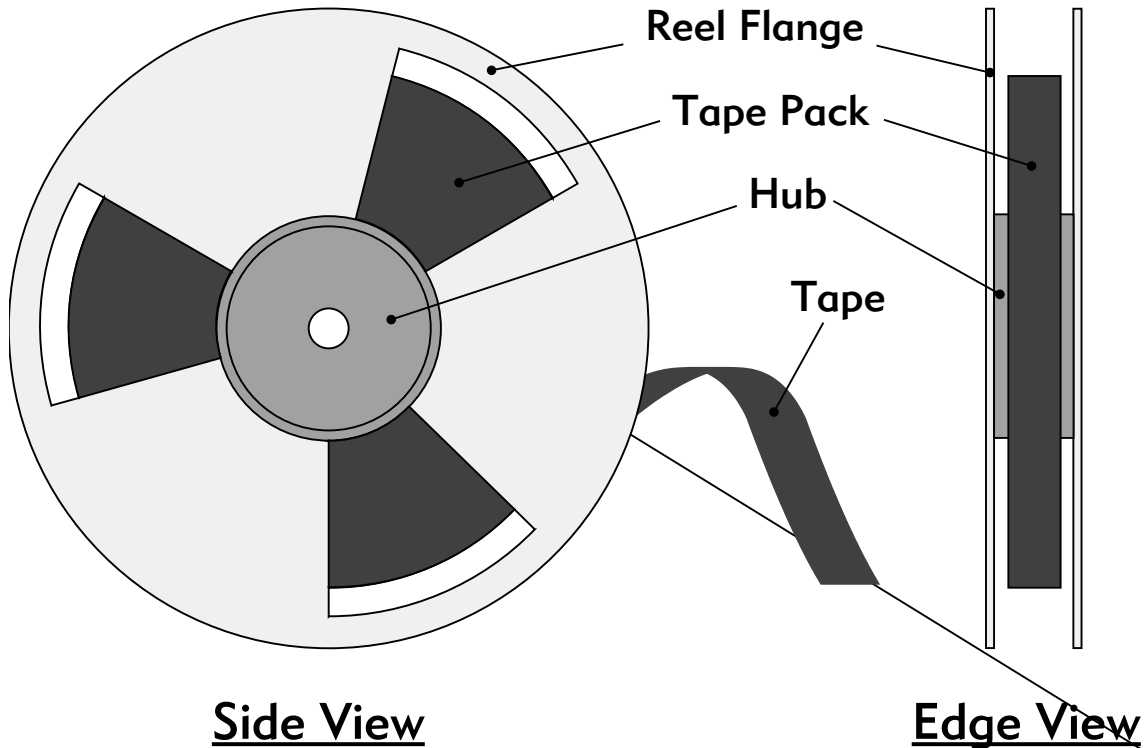

Figure 1. Diagram of a Tape Reel A schematic of a tape reel showing the principal components. Tape is wound around the hub of a tape reel forming a tape pack. The tape pack is protected from damage and disruption by flanges on the reel.

The binder also has the function of providing a smooth surface to facilitate transportation of the tape through the recording system during the record and playback processes. Without the binder, the tape surface would be very rough, like sandpaper. Other components are added to the binder to help transport the tape and facilitate information playback. A lubricant is added to the binder to reduce friction, which reduces the tension needed to transport the tape through the recorder and also reduces tape wear. A head cleaning agent is added to the binder to reduce the occurrence of head clogs that result in dropouts. Carbon black is also added to reduce static charges, which attract debris to the tape.

The backing film, or substrate, is needed to support the magnetic recording layer, which is too thin and weak to be a stand-alone film layer. In some tape systems, a back coat is applied to the backside of the tape substrate layer. A back coat reduces tape friction, dissipates static charge, and reduces tape distortion by providing a more uniform tape pack wind on the tape reel (Figure 1). A schematic diagram of a magnetic tape construction is shown in Figure 2.

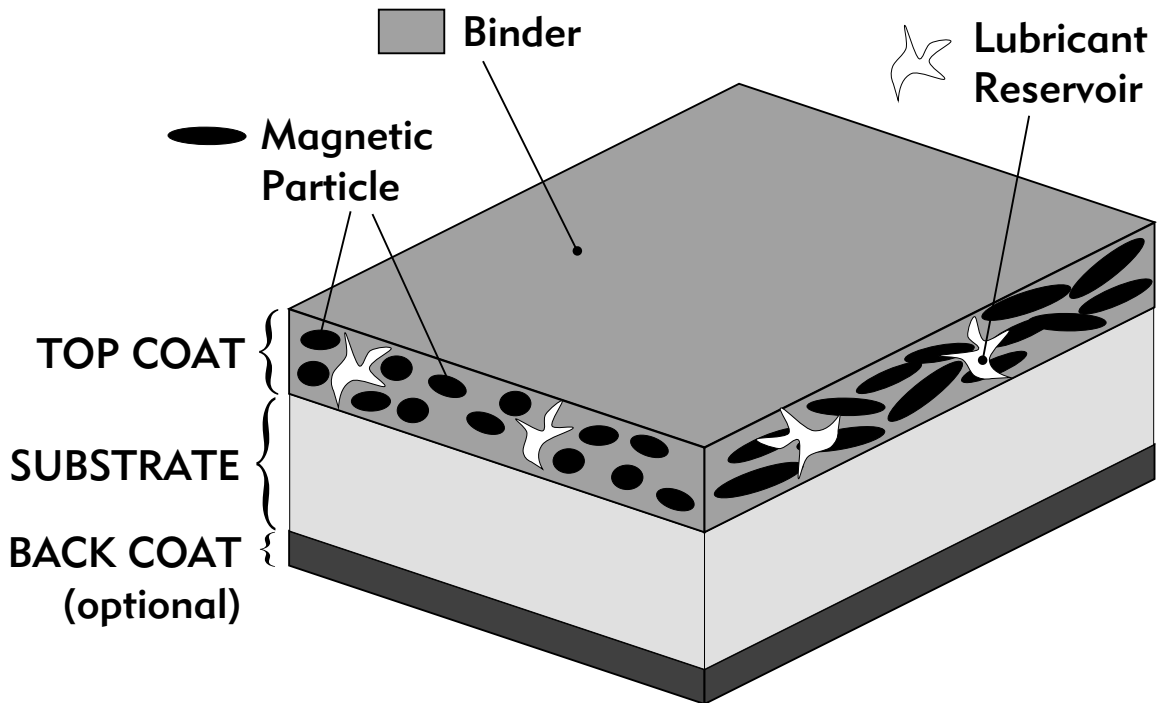

Figure 2. Cross Section of Magnetic Tape Magnetic particles are held together with a binder coated on a film substrate. Lubricant and other agents (not shown) may also be included in the top coat layer. A back coat may also be added to control friction and static charges. The structure of the top coat is analogous to that of Jell-O filled with grapes where the grapes represented the magnetic particles and the Jell-O represented the binder.

All three tape components — magnetic particle, binder, and backing — are potential sources of failure for a magnetic tape medium. The Magnetic-Media Industries Association of Japan (MIAJ) has concluded that the shelf life of magnetic tape under normal conditions is controlled by the binder rather than the magnetic particles (“DDS Specs Drive DAT Reliability,” *Computer Technology Review*, 13 (5), May 1993: 30). In this instance, the shelf life would refer both to the life of recorded as well as unrecorded media; the life of the binder is independent of whether or not the tape has ever been recorded.

2.1 Binder Degradation

The binder is responsible for holding the magnetic particles on the tape and facilitating tape transport. If the binder loses integrity — through softening, embrittlement, loss of cohesiveness, or loss of lubrication — the tape may become unplayable. Sticky tape and sticky shed are commonly used terms to describe the phenomenon associated with deterioration of the magnetic tape binder.

The binder polymers used in magnetic tape constructions are subject to a chemical process known as hydrolysis. In this process, long molecules are broken apart by a

reaction with water to produce shorter molecules. The shorter molecules do not impart the same degree of integrity to the binder system as do the longer molecules. As in a wool sweater, if enough individual yarns are cut, the sweater will eventually fall apart.

Specifically, it is the polyester linkages in the commonly used polyester polyurethane-based binder systems that undergo scission (are broken) by water molecules. Water must be present for the hydrolysis reaction to occur. Furthermore, the more water that is present, the more likely it is that polyester chains will be broken. The binder polymer will absorb water from the air. It will absorb more water in a high humidity environment than a low humidity one. This process is analogous to that observed for open bags of crackers, potato chips, and breakfast cereals: They will lose their crunch quickly on humid, summer days (80 to 90% RH) as they absorb high amounts of moisture from the air. In the winter, however, indoor humidities generally can be lower (10 to 20% RH), less moisture is absorbed from the air, and the snacks never seem to get as stale.

Binder hydrolysis can lead to a sticky tape phenomenon characterized by a softer than normal binder coating, higher friction, and/or gummy tape surface residues. A sticky tape can exhibit sticky shed, produce head clogs, result in stick slip playback, and in extreme cases, seize and stop in the tape transport. Tape binder debris resulting from binder deterioration will result in head clogs that will produce dropouts on a VHS tape when played back. The sticky tape syndrome will result in the squealing of audio tapes as the tape very rapidly sticks to and releases from the playback head.

Procedures such as tape baking can temporarily improve binder integrity, allowing sticky tapes to be played and data recovered. The Ampex Recording Media Corporation reports that treating a sticky tape at 122° F (50° C) for three days will sufficiently firm up the binder coating so that the tape can be played. The effect of the treatment is temporary, and it is recommended that the information on the treated tape be transcribed to new tape within one to two weeks. Tape baking should not be considered a universal panacea for the treatment of sticky tapes. The tape baking procedure was developed for a specific type of degradation phenomenon on specific tape types — hydrolysis of reel-to-reel audio tapes and computer tapes. For other kinds of degradation on other tape types, tape baking may actually cause more damage. Expert advice is recommended.

Lubricant Loss

Lubricants are normally added to the binder to reduce the friction of the magnetic topcoat layer of the tape. Lower friction will facilitate tape transport through the recorder and reduce tape wear. In a VHS recorder, where the tape is wrapped around a rapidly rotating head, low friction is also important as it prevents overheating of the tape. The surface of a magnetic tape is actually quite porous. In some tapes, a liquid lubricant is added to the binder and will reside in these pores, similar to water absorbed in a wet sponge. When the tape passes over a head or a

tape guide, lubricant is squeezed out onto the tape surface, providing a slippery interface between the tape and the guide pin. After passing by the guide pin, the excess lubricant on the surface of the tape is absorbed back into the surface of the tape. The phenomenon is similar to that observed when the surface of a wet sponge is gently pressed and released — water is exuded to the surface when the sponge is pressed and is reabsorbed when the pressure is released.

Over time, the level of lubricant in the tape decreases. Lubricants are partially consumed every time the tape is played. This is all part of their job as lubricants — they are consumed and worn down sacrificially to protect the tape. Some of the lubricant will migrate from the tape to the guide pins and heads of the recorder each time the tape is played.

Lubricant levels decrease over time even in unplayed, archived tape as a result of evaporation and degradation. The lubricants used in some tapes are oily liquids that are volatile and slowly evaporate away over time. Some lubricants are also subject to degradation by hydrolysis and oxidation, just like the binder polymer, and will lose their essential lubrication properties with time.

The information stored on severely degraded magnetic tapes can be recovered, in specific instances, after relubrication of the tapes. By significantly reducing the friction of the magnetic coating with the addition of lubricant, tapes can be made to play back. Prior to relubrication, the tape may have seized in the tape transport as a result of high friction, or the magnetic coating may have been readily torn off the tape backing by a high speed tape head. Relubrication of tapes must be done carefully by experienced individuals. If a tape is over-lubricated, the excess lubricant on the surface of the tape will act as debris and increase the head-to-tape spacing, causing signal losses and dropouts.

2.2 Magnetic Particle Instabilities

The magnetic particle, or pigment (the terminology is a carryover from paint and coatings technology), is responsible for storing recorded information magnetically as changes in the direction of the magnetism of local particles. If there is any change in the magnetic properties of the pigment, recorded signals can be irretrievably lost. The magnetic remanence characterizes the pigment's ability to retain a magnetic field. It refers to the amount of signal that remains after a recording process. The strength of the signal recorded on a tape magnetically is directly related to the magnetic remanence of the pigment. Thus, a decrease in the magnetic remanence of the pigment over time can result in a lowered output signal and potential information loss.

The coercivity characterizes the pigment's ability to resist demagnetization. It refers to the strength of the magnetic field that must be applied to a magnetic particle in order to coerce it to change the direction of its magnetic field. Demagnetization of a tape can result from an externally applied field, such as that produced by a hand-

held metal detector at an airport security check point. A magnetic tape with a lower coercivity is more susceptible to demagnetization and signal loss.

Magnetic pigments differ in their stability — some particles retain their magnetic properties longer than others. Thus, some tapes will retain information, which is stored magnetically, longer than others. Iron oxide and cobalt-modified iron oxide pigments are the most stable pigment types of those used in audio and videotapes. These pigments are generally used in the lower grade audio and low to high grade VHS/Beta videotape formulations. The low coercivity of these pigments disallows their use in high grade audio formulations.

Metal particulate (MP) and chromium dioxide (CrO₂) pigments provide a higher tape signal output and permit higher recording frequencies than the iron oxide pigments, but are not as stable as the iron oxide pigments. A decrease in signal output of two decibel (dB) may be observed over the lifetime of metal particle and chromium dioxide based tapes. However, even with these losses, the output signal will still be better than a comparable iron oxide based tape. A loss in signal will manifest itself as a reduction in the clarity and volume of a sound recording and in the loss of hue and reduction in saturation for a video recording. Chromium dioxide is used in medium to high grade audio tape and some high grade VHS/Beta video tape. Metal particulate is used in high grade audio and 8mm video tape. Metal particulate is also used in most digital audio and digital video tape formulations. The type of pigment used in the audio or video tape formulations is normally indicated in the product literature that comes with the tape. This information can also be obtained from the manufacturer via the toll-free number provided on the literature that accompanies the tape cassette or reel.

There is not much that can be done to prevent the magnetic deterioration that is inherent in the metal particulate and chromium dioxide pigment types. However, the rate of deterioration can be slowed by storing the tapes in cooler temperatures. The level of humidity has little direct effect on the deterioration of magnetic pigments. However, by-products of binder deterioration can accelerate the rate of pigment deterioration, so lower humidity would also be preferred to minimize the degradation of the magnetic pigment.

Metal evaporated (ME) video tapes are prevalent in the 8mm video formats. These tapes require no binder polymer, as the entire magnetic layer consists of a single, homogeneous metal alloy layer that is evaporated onto the tape substrate. These tapes have chemical stabilities similar to those of metal particle tapes. However, because the magnetic coating on an ME tape is much thinner than the corresponding layer on an MP tape, they are generally not as durable and do not hold up well in repeated play or freeze-frame video applications.

2.3 Substrate Deformation

The tape backing, or substrate, supports the magnetic layer for transportation through the recorder. Since the early 1960s, audio tapes and videotapes have used an oriented polyester (also known as polyethylene terephthalate, PET, or DuPont Mylar™) film as a tape substrate material. Polyester has been shown, both experimentally and in practice, to be chemically stable. Polyester films are highly resistant to oxidation and hydrolysis. In archival situations, the polyester tape backing will chemically outlast the binder polymer. The problem with polyester backed videotapes is that excessive tape pack stresses, aging, and poor wind quality can result in distortions and subsequent mistracking when the tapes are played.

The best way to reduce the degree of tape backing distortion is to store magnetic media in an environment that does not vary much in temperature or humidity. Each time the temperature or humidity changes, the tape pack will undergo expansion or contraction. These dimensional changes can increase the stresses in the tape pack that can cause permanent distortion of the tape backing. Distortion of a VHS tape backing will show up as mistracking when the tape is played.

Tape backing deformation can also arise if the tape experiences nonlinear deformation as a result of nonuniform tape pack stresses. This normally results if the tape pack wind quality is poor as indicated by popped strands of tape — one to several strands of tape protruding from the edge of a wound roll of tape. Methods of controlling the quality of the tape pack wind are discussed in the Ampex Guide to the Care and Handling of Magnetic Tape that appears in the Appendix.

Older tapes used other backing materials. In the 1940s and 1950s, acetate (cellulose acetate, cellulose triacetate) film was used as an audio tape backing. This is the same material used in some older movie film. In general, if light can be seen coming through the tape windings when the reel is held up to a light, it is an acetate based magnetic tape. This substrate is subject to hydrolysis and is not as stable as polyester film. However, more stable vinyl binder systems were used during this time period. Thus, the life of tapes produced during this period can be limited by the degradation of the backing rather than the binder. Degradation of the backing in these tapes is indicated by the presence of the vinegar syndrome, where a faint odor of vinegar (acetic acid) can be detected coming from the tapes. In the advanced stages of degradation, the magnetic tape will become brittle and break easily if bent too sharply or tugged. The backing also shrinks as it decomposes, resulting in a change in the length of the recording. Any tape on an acetate backing should be stored in a low-temperature, low-humidity archive to reduce the rate of deterioration of the acetate tape backing.

Acetate film has also been used as a base film for photographic film, cinema film, and microfilm. The "IPI Storage Guide for Acetate Film" has been prepared by the Image Permanence Institute, Rochester Institute of Technology, Post Office Box 9887, Rochester, New York, 14623-0887, Phone: 716-475-5199, as an aid in preserving still

and motion picture film collections on acetate base films. The comments in that guide are equally appropriate for acetate based magnetic recording tape. In general, lower storage temperatures and relative humidities are recommended to increase the time to onset of the vinegar syndrome. Tapes having the vinegar syndrome should be stored separately to prevent the contamination of other archive materials by acetic acid. After the onset of the vinegar syndrome, acetate films degrade at an accelerated rate. Tapes that have been stable for fifty years may degrade to the point of being unplayable in just a few years. Any valuable tape showing vinegar syndrome should be transcribed as soon as possible.

Prior to cellulose acetate, paper was used as a tape backing material. Audio recordings of this type are very rare and should be stored in a tape archive. Although generally stable, these backings are very fragile and subject to tearing or breaking on playback. For this reason, particular care should be taken to ensure that the playback recorder is very well maintained.

2.4 Format Issues

Helical versus Longitudinal Scan Recording

The susceptibility of the recording to loss as a result of dimensional changes in the backing is dependent on recording format. Videotape, which uses a helical scan recording format, is more sensitive to disproportionate dimensional changes in the backing than analog audio tape, which uses longitudinal recording.

Helical (Figure 3). Tracks are recorded diagonally on a helical scan tape at small scan angles. When the dimensions of the backing change disproportionately, the track angle will change for a helical scan recording. The scan angle for the record/playback head is fixed. If the angle that the recorded tracks make to the edge of the tape do not correspond with the scan angle of the head, mistracking and information loss can occur.

Distortion of a helical scan videotape can result in two types of mistracking — trapezoidal and curvature (Figure 4). In trapezoidal mistracking, the tracks remain linear, but the track angle changes so that the playback head, which is always at a fixed angle to the tape, cannot follow them. Curvature mistracking can be a more serious type of deformation where the recorded tracks become curved as a result of nonlinear deformation of the tape backing. Mistracking will result in a video image where some or all of the screen is snowy or distorted. For example, in the case of trapezoidal mistracking, the upper portion of the TV screen may appear normal, whereas the lower portion of the screen may be all static. The appearance on the screen will be similar to the playback of a good tape where the tracking adjustment control has been purposely misadjusted.

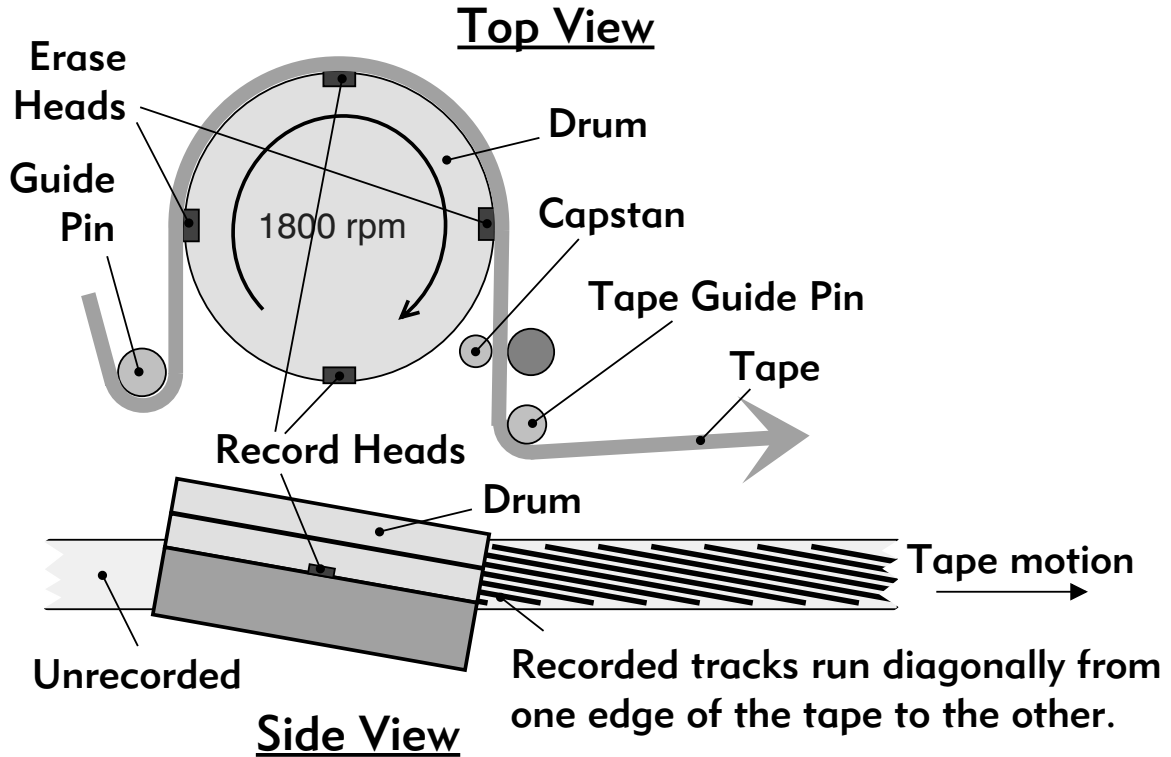

Figure 3. Helical Scan Recording A moving tape wraps 180 ° around a cylindrical drum rotating at high speeds; the rotating head is oriented at a slight angle to the tape so that the tracks written by the tiny record head embedded in the surface of the rotating drum run diagonally across the tape from one side to the other.

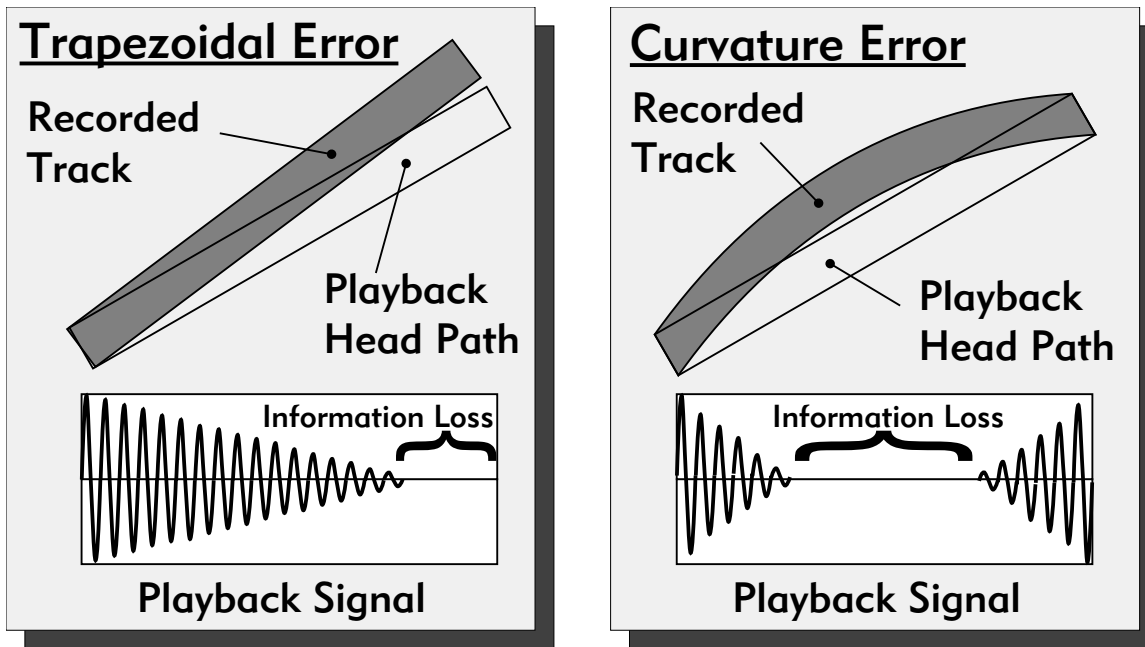

Figure 4. Types of Mistracking for Helical Scan Recording Trapezoidal error occurs when the angle of the recorded track does not agree with the scan angle of the playback head. Curvature error occurs when the tape has deformed nonlinearly. The playback signal corresponds to that for a single helical scan.

Longitudinal (Figure 5). In a longitudinal tape system, the heads are arranged along a fixed head stack — one head per track — and the tracks will always remain parallel to the edge of the tape. Mistracking is not as great a problem in longitudinal recording for this reason.

Distortion of a longitudinal audio recording tape will appear as a temporary muffling, change in pitch, or loss of the audio track. Distortion of the tape backing can impart a slight curve to the normally linear tape. When the distorted portion of tape passes over the playback head, the recorded tracks can move out of alignment with the head gap, causing a temporary reduction in sound volume and quality.

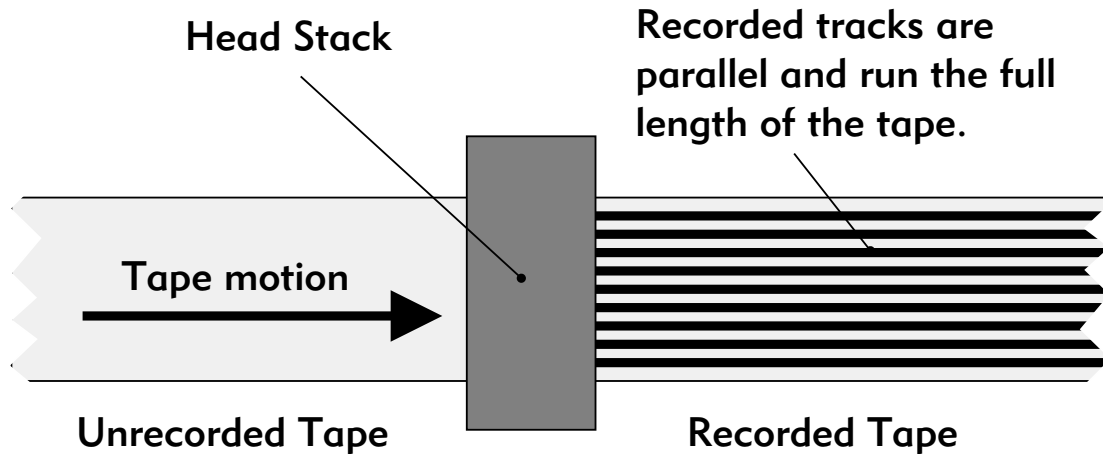

Figure 5. Longitudinal Recording A moving tape passes across a stationary record head. The recorded tracks are parallel to the edge of the tape and run the full length of the tape. A nine-track tape is shown.

Analog versus Digital Storage

Some comments concerning the archival stability of analog versus digital materials may be instructive. In an analog recording, the signal recorded on the audio or videotape is a representation of the signal originally heard or seen by the microphone or video camera. The volume of a sound recording or the intensity of the color of a video image is directly related to the strength of the magnetic signal recorded on the tape. In a digital recording the audio or video source signal is digitized — the signal is sampled at specific points in time and converted to a number that reflects the intensity of the signal at the time of sampling (analog-to-digital conversion). These numbers, in binary form, are written to the tape, rather than the analog signal. On playback, the numbers are read and used to reconstruct a signal that is representative of the original signal (digital-to-analog conversion).

The chief advantage of an analog recording for archival purposes is that the deterioration over time is gradual and discernible. This allows the tape to be transcribed before it reaches a point where the recording quality has degraded to an unusable level. Even in instances of severe tape degradation, where sound or video quality is severely compromised by tape squealing or a high rate of dropouts, some portion of the original recording will still be perceptible. A digitally recorded tape will show little, if any, deterioration in quality up to the time of catastrophic failure when large sections of recorded information will be completely missing. None of the original material will be detectable in these missing sections.

The chief advantage of a digital recording is that copies of the original tape can be made without any loss in recording quality. A copy of a digital tape can be made that is truly identical to the original source tape. When an analog tape is copied, the original information signal is actually copied along with any tape noise inherent in the tape and any electronic noise inherent in the recording device. This will be written to a new tape that also has its own level of inherent tape noise. Therefore,

the noise level on the dubbed copy will always be greater than that on the original tape, or the sound quality of the original recording will be altered as it is filtered to reduce noise. The presence of noise in the recording will make the recorded information less distinct to see or hear. (Recording engineers refer to a signal-to-noise ratio, which defines the quality of the recording with a higher value being better.) Digital tape recordings are virtually unaffected by tape noise, even though digital tapes are not noise free. In digital recording, binary numbers (comprised entirely of ones and zeros) are read from and written to the tape. The ones and zeros are easily distinguished from the background noise. In an analog recording, the recorder cannot distinguish between the recorded signal and the tape noise so that both are read and reproduced on playback. In addition, digital recordings usually have an error correction system that uses redundant bits to reconstruct areas of lost signal.

Analog recording continuously records the complete signal heard or seen by the recording microphone or video camera. However, distortion in both recording and playback will vary with the quality of the electronic components used. In digital recording, the source signal is quantized to a fixed number of allowed signal levels. For example, a video image quantized at 8-bits/color would only allow for 256 distinct colors to be reproduced, whereas an analog image would allow an infinite number of colors. By increasing the number of bits/color used, the number of color levels that can be reproduced will increase (see bit in the Glossary for more detail). For example, an image quantized at 24-bits/color will allow 16,777,216 distinct colors. With digital recording, higher quality video images require greater storage volumes. Some audiophiles with highly trained ears claim that they can hear limitations in a digital CD audio recording (16-bit quantization permitting 65,536 distinct sound levels and a maximum frequency of 22 kHz) when compared to an analog recording of the same sound source.

Analog tape recordings do not require expensive equipment for recording and playing. Digital audio and video equipment which records high frequencies at high speeds and performs the complex tasks of analog-to-digital and digital-to-analog conversion and error correction is relatively expensive.

2.5 Magnetic Tape Recorders

This document is primarily concerned with tape media, not tape recorders. However, in discussing what can go wrong with media, recorders must be mentioned. Audio and video recorders must be maintained in excellent condition in order to produce high quality recordings and to prevent damage to tapes on playback. Dirty recorders can ruin tape by distributing debris across the surface of the tape and scratching the tape. Recorders that are not mechanically aligned can tear and stretch tape, produce poor tape packs, and write poorly placed tracks. Recorders that are poorly aligned electrically can cause signal problems that will result in inferior playback. Follow the manufacturer's instructions for good recorder maintenance in order to protect recordings.

3. Preventing Information Loss: Multiple Tape Copies

As already discussed, this report is primarily concerned with preventing magnetic tape from degrading prematurely. However, it is worth mentioning the use of multiple copies as another strategy for preventing loss of information. Recorded information can be lost because the medium on which it is recorded has deteriorated to the point of being unplayable. Information can also be lost if the tape on which it is recorded disappears (misplaced, stolen, destroyed by fire or flooding, and so forth). Both types of loss can be prevented by maintaining more than one copy of the information and storing all copies in separate locations.

If funds are available, it is preferable to maintain both access storage and archival storage of important information. As the names imply, the access environment keeps the recording readily available for playback. Archive storage involves a separate environment designed to maximize the longevity of the tape. Refer to Section 5.2: Storage Conditions and Standards for a more detailed discussion of these storage conditions.

The quality of care a magnetic tape receives should be commensurate with the perceived value of the information contained on the tape. Refer to Section 4.1: Tape Costs and Longevity for more information. In reality, a library or archive may not have the budget, the personnel, the time, or the space to maintain two copies of all of the recordings in a video or audio tape collection. In this case, the value and use requirements of individual tapes in the collection should be assessed and prioritized. Those tapes considered the most valuable and most likely to be used should be duplicated and the originals should be placed in an archive environment. If duplicates of information are disallowed, some or all of the collection could be placed in an archive, but this would greatly limit access to the information. In instances where the information is considered extremely valuable, it may be worthwhile to maintain several copies of the original in the archive along with the original tape.

4. Life Expectancy: How Long Will Magnetic Media Last?

Unfortunately, media life expectancy (LE) information is largely undocumented, and a standard method for determining magnetic media lifetimes has yet to be established. The need for this information fuels the ongoing NML media stability studies, which have incorporated accelerated temperature/humidity and corrosion environments to measure performance over time and to develop models to forecast extended media lifetimes. A simple example as to how LEs can be determined is provided in the Appendix under Estimation of Magnetic Tape Life Expectancies (LEs).

According to manufacturers' data sheets and other technical literature, thirty years appears to be the upper limit for magnetic tape products, including video and audio tapes. LE values for storage media, however, are similar to miles per gallon ratings for automobiles. Your actual mileage may vary.

Recently, articles have been appearing which suggest that the life expectancy of magnetic media is much shorter than originally thought. For example, an article in the January 1995 *Scientific American* (Jeff Rothenberg, "Ensuring the Longevity of Digital Documents") conservatively estimated the physical lifetime of digital magnetic recording tape at one year. Because of the confusion that can result from such a statement, NML officially responded with a letter to the editor that appeared in the June 1995 issue of *Scientific American*. The letter states that the "physical lifetimes for digital magnetic tape are at least 10 to 20 years."

4.1 Tape Costs and Longevity

Some people assess storage media solely in terms of media cost. This view assumes that the sound, images, or information stored on the media have no intrinsic value. However, a storage medium should be evaluated in terms of the cost of losing the recorded information in the event that the storage medium degrades irreversibly.

The value of the tape cassette must be equated with the cost of preserving the data. When the cost of losing the information is considered, it may be economically justified to invest more in a medium/system of proven reliability. It may also warrant the cost of making and keeping replicated copies of original data and stockpiling systems to play back the data at future times.

When purchasing media of a specific format, some archivists are required to deal with a procurement bidding process. In most cases, the archivist will end up with the lowest bidder's media, which may not be the best media. Tape manufacturers' products differ in coating thickness, magnetic particle stability, and durability. Procurement specifications should exclude the poorer media. The vendor should be asked for experimental proof of the stability of the media if the tape is to be used for archival storage.

4.2 Practical Life Expectancies

Those accustomed to storing paper and microfilm may be annoyed by the relatively short life expectancies (ten to thirty years) of magnetic tape materials. Some gold plated/glass substrate digital optical disk technologies promise 100-year lifetimes. However, a 100-year life expectancy is irrelevant when the system technology may be in use for no more than ten or twenty years (or less).

Audio and video recording technologies are advancing at a much faster rate than printing and microfilming technologies. We are fortunate if a recording technology stays current for more than twenty years. In the case of a magnetic recording media

with a fifty-year life expectancy, the media would undoubtedly outlive the recording system technology. To truly achieve a fifty-year archival life, recording systems, sufficient spare parts, and technical manuals would need to be archived along with the recorded media.

In the case of audio and video archives, transcription is inevitable. Rather than trying to preserve old, outdated recording formats and technologies, it may be more practical to transcribe on a regular basis — every ten to twenty years or even more frequently. The old copy could be preserved until the new copy is transcribed to the next generation of recording system. In this fashion, at least two copies of the material are always in existence.

5. How Can You Prevent Magnetic Tape from Degrading Prematurely?

The remainder of this document answers this question. Some of the factors to be discussed are more controllable than others. For example, you can normally decide the storage conditions and level of access to an archive collection. However, you do not always have control over the quality of the tape wind, or the brand, type, and format of the tape media on which the information is stored.

Factors affecting the life of the tape over which you have some control are:

- The care with which it is handled and shipped, discussed in Section 5.1: Care and Handling.
- The quality of the conditions in which it is stored, discussed in Section 5.2: Storage Conditions and Standards.
- The number of times the tape is accessed during its lifetime, discussed in Section 5.1: Care and Handling: Frequent Access.

Other factors that affect media over which you have less control are:

- The physical components of the tape, discussed in Section 2: What Can Go Wrong with Magnetic Media?
- The quality of the tape being purchased; for example, standard grade versus high grade VHS.
- Variation in the quality of the manufacturer; for example, a name brand versus a bargain brand.
- Future availability of system technology to play back the tape. For example, quadruplex videotapes still exist in archives; however, the equipment to play them back is considered obsolete, and it is difficult to find working recorders.

5.1 Care and Handling

Magnetic tape should receive the same kind of care that you would give to a valuable book or important photograph. In general, handle the tapes with care, keep them clean, and apply common sense:

- Use and store magnetic tape reels and cassettes in a clean environment.
- Avoid contamination of the tapes by dirt, dust, fingerprints, food, cigarette smoke and ash, and airborne pollutants.
- Take care not to drop tapes or cartridges.
- Keep tapes out of strong sunlight and avoid contact with water.
- Do not store tapes on radiators, window sills, televisions, electronic equipment, or machinery.
- When the tapes are not in use, they should be placed back on the storage shelf, and stored on end. They should not be allowed to lay flat (reel flanges parallel with the table top) for extended periods of time.

Refer to the Ampex Guide in the Appendix for more information.

Magnetic tapes do require some unique care and handling precautions. Because they are a magnetic form of storage, exposure to strong magnetic fields must be avoided to prevent information loss. This is generally not a problem, unless the materials need to be transported or shipped.

Frequent Access

Tapes that are frequently accessed may have a reduced life expectancy due to wear and tear. The life of the media may not be determined by data error rates, but by the life of the media housing. In one instance, the life of a tape cassette was limited by failure of the cassette door, not because of any fault of the tape media. How many insert and eject cycles will your media be required to handle? This may limit the life of the cassette.

The more a tape or cassette is handled, the more it is contaminated with fingerprints and debris. It is also exposed to less than ideal conditions, especially if the materials are removed from the building in which they are normally stored.

Every time a VHS cassette is loaded into a recorder, the recorder mechanism pulls tape from the cassette. This mechanism can damage the tape if the guide pins are not properly aligned. Debris on the loading mechanism can scratch the surface of the tape. Also, when a tape is removed from a recorder, the tape must properly retract into the cassette, otherwise it will be damaged when the cassette doors close and the tape cassette is ejected from the recorder. Most of us have probably had experience with a VHS deck that has eaten a tape.

Because of potential damage to the tape, it is important that the tapes be inserted and ejected at areas of the tape that contain no recorded information. A tape should NEVER be ejected in the middle of an important recording.

Transportation of Magnetic Tape

Care must be exercised to ensure that tape collections are not harmed when they are transported. When magnetic media are transported, temperatures should not exceed 110° F (43° C). Collections should be transported in the spring or the fall when outdoor temperatures are moderate, if possible. Properly wound tape reels can survive greater variations in temperature and humidity without permanent damage than can poorly wound tape packs.

Tapes and cassettes should be shipped in the same orientation as they are stored — on edge — with the weight of the tape pack being supported by the reel hub. Tapes that are shipped in the flat position are particularly subject to damage from dropping and other forms of shock. This is especially true of tapes that experience large changes in temperature during shipment or tapes that are poorly wound.

Media should be protected from damage due to shock by packing them in materials that will absorb shock (special packages, bubble wrap), using special labeling, and transporting them in appropriate vehicles. Shock-absorbing packaging will often have the added advantage of providing insulation that helps protect the media from large swings in temperature and humidity.

Exposure to strong magnetic fields must also be avoided to prevent information loss. Some of the detectors used to screen luggage in overseas airports have been known to partially erase tapes. Walk through metal detectors and X-ray scanners do not pose a threat to recorded information. Some hand-held metal detectors can cause problems since they use strong magnetic fields. Refer to the section on Stray Magnetism in the Ampex Guide in the Appendix.

5.2. Storage Conditions and Standards

Storing magnetic tape in a clean, controlled environment is the most important precaution you can take to extend the life of the media. High temperatures, high humidity, and the presence of dust and corrosive elements in the air all affect the physical components that make up magnetic tape and can result in loss of readable data through decreased magnetic capability and deterioration of the binder or backing of the tape. Too low temperatures should also be avoided. In some cases, temperatures lower than 32° F (0° C) may actually harm the media and shorten, rather than extend, life expectancies by risking exudation of the lubricant from the binder, which may clog heads. Rapid temperature changes are also undesirable as they introduce stresses in the wound tape pack. Tapes that are to be played in an environment different from the storage environment should be allowed to acclimate to the new temperature.

Temperature and Relative Humidity

For years tape manufacturers have recommended that you store your tapes in a cool, dry place. In Section 2: What Can Go Wrong with Magnetic Tape?, the reasons behind this dictum were discussed in terms of the chemistries of the tape components: Binder hydrolysis is dependent on the moisture content of the tape, and lower humidity results in lower rates of hydrolysis. Furthermore, this reaction will proceed more slowly at lower temperatures. The latter is also true for the magnetic pigments — they will degrade more slowly at lower temperatures. Finally, to reduce unnecessary stresses on the wound tape that could result in deformation of the backing, a limited variation in temperatures and humidities is recommended. (See Figure 6.)

Storage at high temperatures ($> 74^{\circ}\text{F}$; $> 23^{\circ}\text{C}$) increases tape pack tightness. This results in distortion of the tape backing and an increase in permanent dropouts as wound-in debris is forced into the tape magnetic layer. Many layers of tape before and after the debris can be affected by impressions of the debris. Layer to layer adhesion, known as tape blocking, also can result after long term storage at elevated temperatures.

Storage at high humidity ($> 70\% \text{RH}$) results in increased degradation of the binder as a result of the higher moisture content of the tape pack. High humidities will also cause increased tape pack stresses as the tape absorbs moisture from the air and expands, causing distortion of the tape backing and an increase in permanent dropouts.

Fungal growth is also possible at high humidities and temperatures. Molds can live off the binder polymer and added components. This is yet another cause of binder breakdown in high humidities. Hairy growths at the edges of the tape are a sign of mold. The spores that are produced on this fuzz can get onto the tape surface and cause many dropouts.

Changes in both temperature and humidity can also cause mistracking problems on helical scan recordings (See Section 2.4: Format Issues: Helical versus Longitudinal Scan Recording). Substrates will expand or shrink with changing temperature and humidity just as metals do in heat or cold. The substrate films are not completely balanced in their reaction to these changes in temperature and humidity. In other words, they stretch and shrink differently in length and width directions. This causes a change in the angle of the recorded helical scan tracks. Most of these changes are recoverable by returning to a temperature and humidity close to the one at which the tape was recorded. However, heat can also cause premature aging of the substrate in the form of nonrecoverable shrinking and stretching.

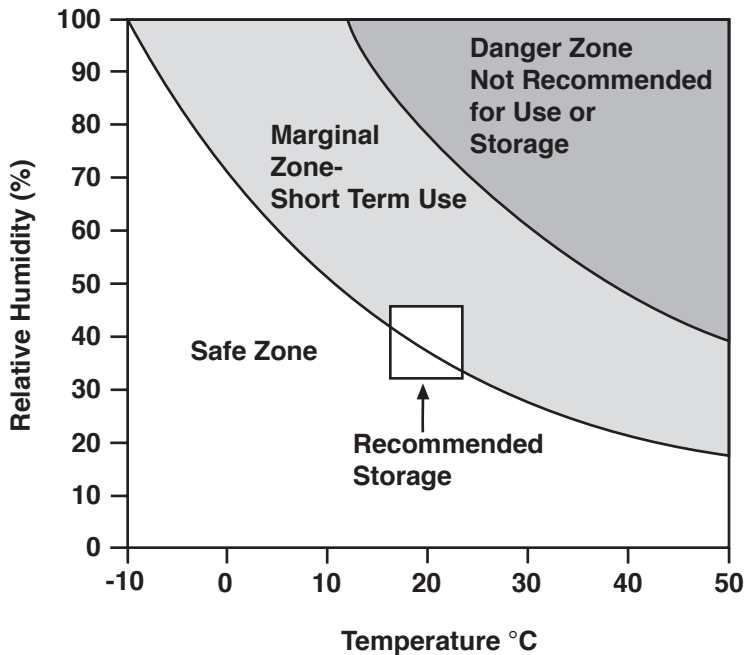

Figure 6. Temperature and Humidity Conditions and Risk of Hydrolysis This figure depicts the effects of humidity and temperature and shows that $15 \pm 3^\circ \text{C}$ ($59 \pm 5^\circ \text{F}$) and 40% maximum relative humidity (RH) are safe practical storage conditions. A similar diagram appears in ISO TR 6371-1989 that suggests even more stringent conditions (RH 20% max.) for long-term storage of instrumentation tapes. (Source: Ampex. Reprinted with permission.)

Variations in Temperature and Humidity

Generally, the temperature and humidity in a tape storage facility are set to specific values, or set points, and infrequently varied or adjusted. This does not mean that the temperature and humidity in the facility are invariant. Changes in the outdoor temperature and humidity will cause the temperature in the tape storage facility to vary slightly.

If the temperature outdoors is higher than the set point temperature in the facility, the actual temperature in the facility will be slightly higher than the set point. If the outdoor temperature is lower than the set temperature, the actual facility temperature will be lower than the set point. The variations in temperature experienced will be larger at larger distances from the thermostat in the facility. The same logic applies to the humidity level in the facility. Larger discrepancies in the set point and the actual temperature will be observed if one of the walls of the facility is an exterior wall, or if the heating/cooling capacity of the environmental controller is less than that required to properly control the tape archive.

The set point in a tape archive may be constant, but the archive will still experience some degree of daily and seasonal variations in temperature and humidity. A tape archivist must have knowledge of the set points in the archive as well as the

variations in temperature and humidity to ensure that the archive complies with recommended storage conditions.

Variations in temperature and humidity can cause tape problems. Tape packs are wound under a considerable amount of tension. This is necessary to maintain the shape of the tape pack. A reel of tape can be permanently damaged if the tape pack tension is too high or too low. If the tension is too high, the tape backing can stretch. If the tension gets too low, tape layers can slip past each other, resulting in pack slip, cinching, or popped strands on playback (see Figure 7). Relaxation of the tape backing can also occur if the tape pack tension is not properly maintained. Relaxation, stretching, and deformation of the tape backing can cause mistracking of a videotape or sound distortion on an audio tape. Every time a tape pack is heated or cooled, the tape pack tension will increase or decrease, respectively. The best way to reduce the degree of tape backing distortion is to store magnetic media in an environment that does not vary much in temperature or humidity.

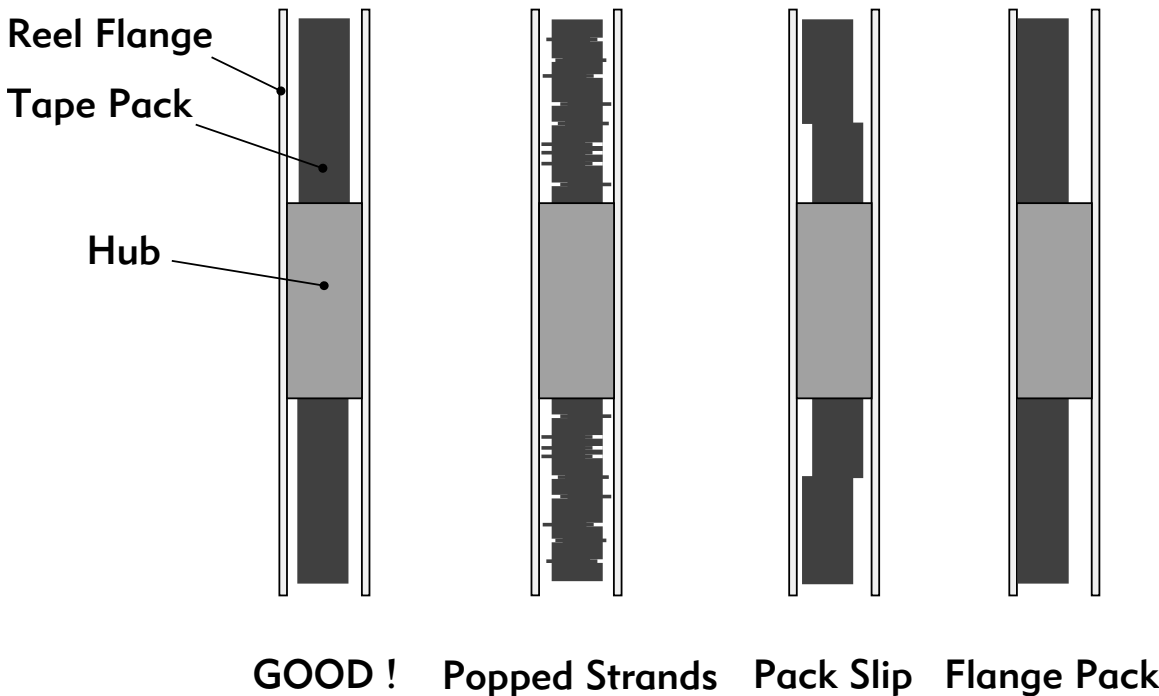

Figure 7. Bad Tape Wind Examples This figure shows schematic examples of popped strands, pack slip, and a flange pack. The illustrations show a cross-section slice of the tape pack through the hub.

Dust and Debris

Dust, smoke particles, and tape debris present in the environment can get wound into the tape pack as the tape is played, resulting in dropouts when the tape is subsequently played. The lost signal is generally greater than expected from the size of the particle. The record and read heads must maintain very close contact with the

tape. A particle of dust on the tape causes the head to ride up over the particle and lose contact with the tape. For perspective on the size of various debris particles compared to the normal head to tape spacing, see Figure 8.

Debris Perspective on High Density Digital Recording Tape

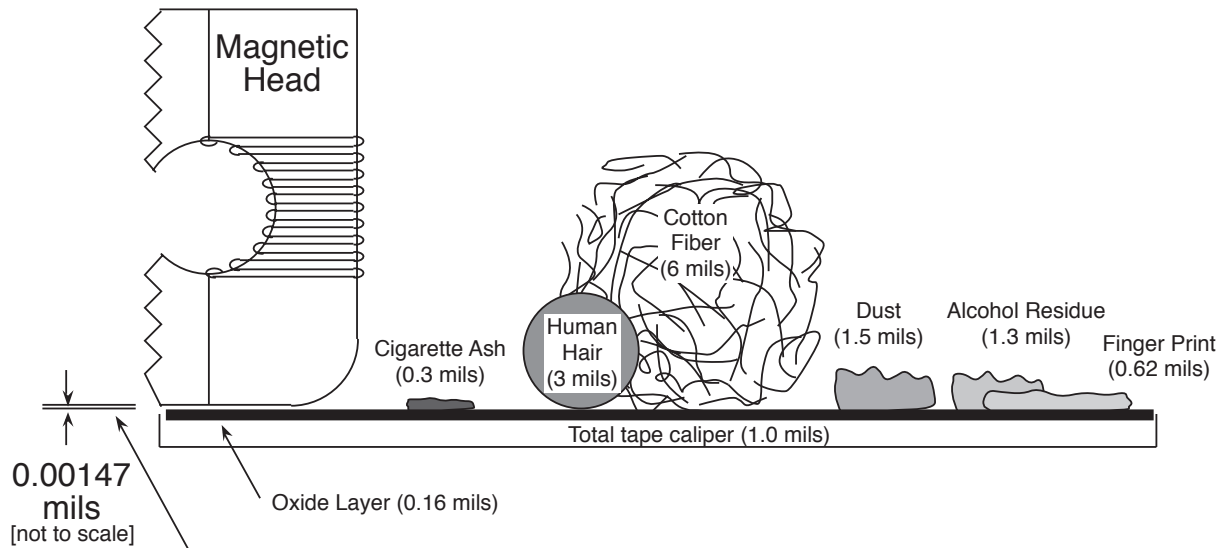

Spacing which would cause a 2 dB loss at 50 Kfci

Figure 8. Size of Tape Debris Relative to the Tape/Head Spacing This figure shows the relative size of debris commonly found on tapes and on recorders relative to the tape-head spacing. It is clear from this diagram that even the smallest airborne particles can result in a dropout if the debris gets between the head and the tape.

Corrosive Gases

Polluted air is known to cause problems with books, photographs, and works of art. Airborne sulfides, ozone, and nitrous oxides can cause accelerated deterioration of these objects. Silverware and black and white photographs are blackened by airborne sulfides produced by the degradation of wool fibers, the burning of coal, and bioeffluents. Magnetic tapes are no exception. They, too, are susceptible to corrosive gases in the environment.

Exposure to very low levels of corrosive gases representative of urban office environments has been known to cause corrosion on bare metal particle (MP) and metal evaporated (ME) tapes. In general, these tapes are contained in cassettes, and the cassette shells have been shown to be an effective armor against pollutants in the environment. This corrosion problem is limited to the metal based MP and ME tapes and is not a significant factor in the deterioration of oxide tapes (iron oxide, chromium dioxide, barium ferrite).

If a tape archive is known to contain MP or ME based magnetic tapes, and the tape archive is situated in an environment characterized by high levels of pollutants (e.g., downtown Los Angeles), some precautions may be necessary to ensure that the level of chlorine and sulfides in the archive are at a sufficiently low level. Air conditioning systems may require special filters to remove pollutants if the archive is located in an urban environment.

Storage Recommendations

Current industry standards recommend that materials be stored around 65 - 70° F (18 - 21° C) and 40 - 50% relative humidity (RH) (Table 1). Unfortunately, these recommendations are based, in part, on what is best for recording and playback, and what has historically proven to be good for film and paper storage. They may not be the best conditions for the long-term storage of magnetic media. Standards committees are beginning to consider storage conditions specific to magnetic tape and are recognizing that magnetic tapes benefit from storage at temperatures and humidities lower than those recommended in the past.

Agency/Researcher	Date	Temperature	Relative Humidity
Cuddihy	1982	65° F ± 3° F 18° C ± 2° C	40% ± 5%
SMPTE (RP-103)	1982	70° F ± 4° F 21° C ± 2° C	50% ± 20%
NARA	1990	65° F ± 3° F 18° C ± 2° C	40% ± 5%

Table 1. Current Recommendations for Magnetic Tape Storage

Note: These are general recommendations that were being made in the 1980s. Standards committees are beginning to recognize the benefits of lower humidities and temperatures for the long term storage of magnetic tape. The above conditions may not be optimal for preserving magnetic tape for as long as is physically possible.

AES, ANSI, NARA, and SMPTE standards committees are coming to recognize that organizations have different storage needs and requirements. In some cases, information older than five years is considered obsolete. In other cases, information needs to be preserved in perpetuity. The optimal storage conditions for each of these requirements differs (Table 2). In the case of short-lived information, storage conditions can be at or near the room ambient conditions of the facility in which the tape collection is housed. No special storage facilities would be required, assuming that temperatures stayed between 68 - 76° F (20 - 24° C) year round and humidity never exceeded 55% RH. For the indefinite storage of information, special storage facilities would be required to maximize the lifetime of the media. No medium lasts forever, so transcription of information from old, deteriorating media to new

media would eventually be required; however, storage conditions can be optimized to preserve the current media copy of the information for as long as possible.

Information stored at room ambient conditions would be readily accessible and playable. On the other hand, information stored in deep archive conditions would require a period of time to acclimate to the conditions of the facility in which the information would be played back. As such, the storage condition recommendations are generally referred to as access storage and archive, or preservation, storage.

Key Feature	Access Storage	Archival Storage
Function	To provide storage for media that allows immediate access and playback	To provide storage that preserves the media for as long as possible
Acclimation required prior to playback?	No.	Yes.
Media Life Expectancy	At least 10 years when stored at the indicated temperature and humidity conditions.	The maximum allowed for the particular media type.
Temperature Set Point	At or near room ambient. In the range: 60 to 74 ° F (15 To 23 ° C)	Significantly lower than room ambient. As low as 40 ° F (5° C).
Humidity Set Point	At or near room ambient. In the range: 25 to 55 % RH.	Significantly lower than room ambient. As low as 20 % RH.
Temperature Variations	Difference between maximum and minimum value should not exceed 7 ° F (4° C).	Difference between maximum and minimum value should not exceed 7 ° F (4° C).
Humidity Variations	Difference between maximum and minimum should not exceed 20 % RH.	Difference between maximum and minimum value should not exceed 10 % RH.

Table 2. Key Features of Access and Archival Storage of Magnetic Tape

Information represents a general summary of conditions being proposed in drafts of storage recommendations by SMPTE, ANSI, AES, and others.

Access storage conditions are recommended for those materials that need immediate access for playback purposes and for information that has a functional lifetime of ten years or less. Access storage conditions are close to the temperature and humidity conditions of the playback facility — generally room ambient

conditions. The single, one-size-fits-all storage condition recommended for magnetic tape in the 1980s and early 1990s generally fit the category of access storage.

Archival storage conditions are recommended for materials that need to be preserved as long as possible. The conditions are specifically designed to reduce the rate of media deterioration through a lowering of the temperature and humidity content of the media. The temperature and humidity are also tightly controlled to reduce the deformation of the tape pack as a result of thermal and hygroscopic expansion/contraction.

Considerable cost is normally involved in maintaining a temperature/humidity controlled archive. However, as mentioned elsewhere in this report, the quality of care a magnetic tape receives should be commensurate with the perceived value of the information contained on the tape. If the information stored on the tape is of great value and must be preserved indefinitely, this could justify the cost of purchasing and maintaining the recommended archive facility. See Section 4.1: Tape Costs and Longevity for more information.

Removal of Magnetic Tapes from Archival Storage

Tapes cannot be immediately removed from archival storage conditions and played on a recorder. Time must be allowed for the tapes to equilibrate to the temperature and humidity of the recorder environment prior to playback. This allows the stresses in the pack to equalize and the track shapes (helical scan) to return to normal. In the case of very low temperature storage, it may be necessary to place the tapes in an intermediate storage environment first to prevent condensation of moisture on the tapes and reduce stresses on the tape pack that would be introduced by rapid temperature changes.

In general, it is the width of the tape that determines how rapidly it will come to equilibrium. A tape that is twice as wide will take four times as long to stabilize to the new environment. Table 3 indicates the amount of time that should be allowed for the tapes to come to equilibrium after significant changes in temperature and/or humidity ("Heat and Moisture Diffusion in Magnetic Tape Packs," IEEE Transactions on Magnetics, 30 (2), March 1994: 237).

Tape Format	Time for Temperature Acclimation	Time for Humidity Acclimation
Compact audio cassette	1 hour	6 hours
1/4-inch reel-to-reel	1 hour	1 day
2-inch reel-to-reel	16 hours	50 days
VHS/Beta cassette	2 hours	4 days
8mm video cassette	1 hour	2 days
U-matic cassette	4 hours	8 days

Table 3. Acclimation Times for Magnetic Media Removed from Archival Storage A tape that is stored at a temperature or humidity that is significantly below that of room ambient conditions must be allowed to acclimatize prior to playback.

5.3 Refreshing of Tapes

In order to maximize their useful life, tapes may require periodic refreshing. This is a nonstandard term in the tape recording trade that can refer to the retensioning or rerecording of the tape, depending on the community of tape users. To avoid confusion, the terms retensioning and rerecording are preferred to refreshing.

Retensioning is normally recommended where prolonged tape pack stresses could cause damage to the tape. Some manufacturers have recommended that tapes be unspooled and rewound at regular intervals (often three years) to redistribute tape stress and prevent tape pack slip, cinching, and tape backing deformation. For example, retensioning was often recommended for large diameter tape reels, such as the old twelve-inch quadruplex videotape reels, so that tape stresses near the hub of the reel could be relieved. Some tape user communities refer to the process of retensioning as exercising the tape.

Rerecording requires that data be read from and written to the same tape periodically to refresh the magnetic signal and prevent data loss. Rerecording was employed primarily with some older nine-track computer tapes used in the 1960s and 1970s that were susceptible to print through.

Transcription, the copying of one tape to another, has also been referred to as refreshing. Transcription is the preferred term for this process. Tapes purchased today generally utilize small diameter tape reels and high coercivity magnetic pigments so that they often do not require retensioning or rerecording on a periodic basis. In some specific instances, tape manufacturers may still recommend the periodic retensioning of tape (see Ampex Guide in the Appendix, for example). It is best to check with the manufacturer to determine if tape retensioning is necessary.

Finally, refreshing should not be confused with restoration. Refreshing is a preventative maintenance procedure. Restoration refers to the reconditioning of a damaged or degraded tape in order to allow playback. Restoration is a repair or damage recovery procedure.

Appendix

Ampex Guide to the Care and Handling of Magnetic Tape

The Ampex Recording Media Corporation, a U.S. magnetic tape manufacturer, has developed many informational and training materials about magnetic tape. The “Guide to the Care and Handling of Magnetic Tape” is reproduced here with the permission of the Ampex Recording Media Corporation. Additions, changes, and comments by NML are shown in square brackets []. Some of the sections of this document deal with recorder aspects that may be beyond your control, such as wind speed and tension, if you are using a simple VHS, cassette, or reel-to-reel audio deck. However, these sections still contain useful information on what to look for as signs that the tape is damaged or needs to be copied. All sections of the original document are included for completeness, but not all sections may be appropriate for your particular tape collection.

Recommended Practices

- Tape should be handled only in no smoking, no food, clean areas.
- Do not let tape or leader ends trail on the floor.
- [Do not drop or subject to sudden shock.]
- Keep tape away from magnetic fields. Don't stack tapes on top of equipment.
- Tape storage areas should be cool and dry. Never leave open reel or cassette tapes exposed to the sun.
- Avoid subjecting tapes to rapid temperature changes. If storage and operating area temperatures differ by more than 15° F (8° C), allow an acclimatization time within the operating area of four hours for every 18° F (10° C) difference.
- Store open reel and cassette tapes with the reels or tape packs vertical. Reels should be supported by the hub. [Tapes should be stored like books on a library shelf — on end. They should not be stored laying flat.]
- Use high quality reels or cassettes, boxes/containers, and accessories.
- Return tapes to their containers when they are not in use.
- Cut off damaged tape or leader/trailer ends from open reel tapes.
- For open-reel tapes, use protecting collars if available.
- Do not use general purpose adhesive tapes to secure the tape end or for splicing. If necessary, use adhesive products designed for the purpose.
- Minimize tape handling.
- Do not touch the tape surface or the edge of the tape pack unless absolutely necessary and then wear lint-free gloves.
- Clean the recorder tape path thoroughly at the recommended intervals.

- Discard tapes with scratches or any other surface damage, which causes significant debris to be left in the recorder tape path.
- Ensure tapes to be reused are thoroughly bulk-erased before they are put back into service.

Cleanliness

Cleanliness is important because minute debris can cause loss of reproduced signal by disturbing the intimate contact necessary between the tape surface and the reproducing head. Figure 9 shows typical dimensions of common contaminants in the context of significant tape to head separation. A separation less than 1/10th of the diameter of a smoke particle will cause a 12 dB loss, reducing the signal to 1/4 of the proper amplitude.

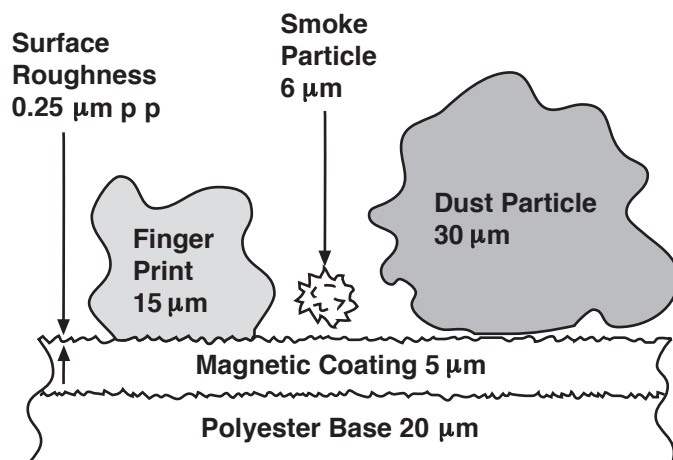

Figure 9. Tape Debris. (Source: Ampex. Reprinted with Permission.)

For analog recording, especially audio recording, the effects of dirt and debris are much less important than for high density digital recording and video recording. Relatively severe dropouts will be unnoticed in analog hi-fi reproduction and even worse dropouts will not impair the intelligibility of speech.

Dropouts are much more important in instrumentation data recording and any form of high density digital recording. If the signal losses are sufficiently severe to overwhelm the error correction, data errors may result.

In video recording, very short duration dropouts appear as irritating flashes in the picture, and in this case, perhaps unusually, the eye is more critical than the ear. For any type of recording, things are not as difficult as they appear because spacing due to debris is confined to only a small part of the track width, but the message for tape care is clear. However, most physical tape damage occurs when tapes are being loaded on a recorder or during handling before or after loading. It is, therefore, preferable that tapes be kept clean to avoid the need for special cleaning that involves extra handling and passage through additional mechanisms. For general

purpose tapes, a class 10,000 clean room environment (less than 10,000 0.5 mm particles per foot) is a good aim. High density digital recording may benefit from cleaner conditions.

The worst contaminants, which should never arise, are sticky residues from improper tape end fixing tabs or elsewhere. Special end retaining tape or tabs have non-oozing clean peeling adhesive.

Stray Magnetism

This is less of a problem than often thought. Devices such as walk-through metal detectors use small fields that have absolutely no effect. Hand-held detectors are best avoided as high local fields may be present. X-rays have no effect on unrecorded or recorded tapes. Similarly, radiation from radar antennas can be disregarded, unless the field strengths are sufficient to injure people. [Some detectors used to screen luggage in airports use powerful magnetic fields that may partially erase recorded information on tapes. These devices are used in some European airports.]

It is prudent to keep tape away from transformers, heavy electrical machinery, [and other very strong magnets]. Magnetizing forces of the order of 500 A/m and above can cause partial erasure and/or increase print through in the case of recorded tape. Such fields may put low frequency (LF) noise on unrecorded tape. This can be removed by bulk-erasure. The risk of increased print through applies to alternating fields that can act as a bias, encouraging layer-to-layer printing.

Magnetic field problems are very rare, even for tapes shipped internationally without special precautions. The best protection for shipping is a minimum of 50 mm [2 inches] of nonmagnetic material all round. The inverse square law ensures that the fields from even heavy electrical equipment will not affect tape at 50 mm [2 inch] distance. Metallic boxes and foils offer no useful protection against stray fields but may help exclude adverse environments.

Tape Handling

General

Cassettes provide good protection for the tape inside. Cassettes should be returned to their library boxes for additional protection when not in use.

The protection offered by reels can be improved if wrap-around collars fitting around or between the flanges are used. Such collars prevent the flanges deflecting and pressing against the edge of the tape; they also help exclude dust and retain the tape end, avoiding the risk of contamination with glue from unsatisfactory retaining tabs.

[Shock, such as dropping the tapes, should be avoided.]

Tape edge quality

Tape is slit to precise widths with smooth straight edges. These qualities must be preserved if the tape is to perform well, [since most recorders edge guide the tape].

Modern recorders use narrow tracks. [If a tape edge is nicked, dented, bent or stretched] the recorder head [will not properly track over the recorded signal (mistracking)]. Bent or nicked reels, therefore, should be promptly discarded before significant tape edge damage results.

If an uneven tape pack is noted within a cassette, it may be appropriate to copy any valuable data for the same reason.

Tape pack/wind quality

Tape is least vulnerable to external damage when wound in a smooth, even pack. Popped strands, where a few turns of tape stand away from the majority, are very easily damaged and should be avoided by using good quality tape and properly adjusted recorders.

Wound tape packs tend to loosen at low temperature (the tape thickness shrinks faster than the length). [This can also occur if the tape has reached high temperature and/or humidity and is brought back down to access conditions]. Vertical storage prevents pack slip under such conditions. Supporting reels by their hubs ensures the flanges are not deflected. In the ideal case, the flanges will then not contact the tape.

[Flange packing is a condition that occurs when the tape is either wound up against one flange by a poorly aligned recorder, or has fallen against the flange due to a loose wind and flat storage. Flange packing often leads to damaged edges from the tape scraping against the edge of the flange as it unwinds through the recorder or winds back to the reel. When a poor wind with popped strands is also present, the strands that stick out of the pack can be severely bent when the tape is flange packed.]

Embossing

Reels should have smooth tape take-up surfaces. Even small bumps close to the hub will produce impressions in the tape repeating for several tens of meters. This embossing effect applies for lumps as small as 30 mm [1.2 mil; 0.0012 inch] high, and the impressions produce measurable tape-from-head separation. Note that even well-made splices stand higher than 30 mm so the embossing effect applies.

A wrinkled tape end on the hub can cause similar problems. A wrinkled or frayed end at the beginning of a tape is likely to deposit debris in the recorder tape path before embossing the tape as it winds onto the take-up reel.

Winding speed and tension

As indicated above, a smoothly wound pack is always desirable. A nominal winding tension in the region of 2.2 N [8 ounces] is appropriate for 25.4 mm [1 inch]

wide tape with nominal thickness 25 mm [1 mil; 0.001 inch]. For other widths and/or thicknesses, the tension may be adjusted pro-rata. At slow winding speeds (< 381 mm/s [15 inches/sec]), very little air is trapped in the pack as it is wound, and there is a negligible air lubrication effect. In these conditions, lower tension may be desirable.

Excessive tension (at any speed) leads to a tape pack showing radial lines known as spokes. These radial lines result from the pressure from outer layers in the pack compressing the inner layers so that the turns develop a small kink. These kinks align radially and appear as a spoke [when you look through the flange at the edge of the tape].

In severe cases, the periphery of the tape pack may lose its smooth round form and become lumpy. A tape showing any such signs of distress should be rewound immediately, ideally at a low speed (e.g., 760 mm/s [30 inches/sec]) and any valuable data copied. The tape may return to normal, but there is a risk of the edges having been stretched more than the center, which leads to wrinkled edges and subsequent tracking and tape-to-head contact problems.

Several different winding tension control systems are popular. Most tape leaving the factory is wound with constant torque. Many recorders wind with constant tension. There is also the so-called programmed winding tension advocated by several U.S. Government agencies. In this case, the tape is wound with low tension close to the hub. Increased tension is applied midtape and then the tension reduces again as the outer diameter is approached. A plot of tension (vertical axis) versus tape length (horizontal axis) gives rise to another name for this technique, which is the bathtub curve approach.

This special technique yields a pack with certain types of tape that survives a particular sequence of temperature and humidity cycles very well, but either constant tension or constant torque winding is perfectly satisfactory for normal applications and storage conditions.

Periodic rewinding

For long-term storage, it is helpful to rewind tapes at an interval of not more than three years. This relieves tape pack stresses and provides early warning of any problems.

Rotary Head Recorders

Tape scratches and head clogging

All the foregoing considerations apply equally to stationary head and rotary head [VHS; 8mm] recorders; however, the much greater head-to-tape speed associated with the latter can lead to special problems if the tape becomes scratched. Tape scratches may be inflicted by damaged heads or a sharp surface somewhere along the tape path.

Scratches can also be caused by mobile debris reaching the spinning head area. In such cases, high temperatures can result at the head-to-tape interface, and a blob of molten debris can become welded to the head. This solidifies and, as it spins on the head, inflicts more damage on the tape. A head with such a damaging attachment neither records nor reproduces properly and is said to be clogged. It is, therefore, very important to be scrupulous in following the cleaning procedure recommended by the recorder manufacturer.

If there is any suspicion of tape scratching, the recorder tape path and heads should be cleaned immediately to avoid risk of damage to other tapes. Similarly, a scratched tape should be taken out of use as soon as possible to avoid the risk of clogged heads and damage to other tapes. Once a tape is scratched, its surface integrity is lost, and it will tend to clog on even the most perfect recorder.

Estimation of Magnetic Tape Life Expectancies (Les)

Magnetic tape degrades by known chemical processes. When the kinetics of these processes is fully understood, the degradation mechanisms can be modeled and the life expectancy (LE) of tapes can be estimated. The binder systems used in today's audio and videotapes are generally based on polyester polyurethanes. These polymers degrade by a process known as hydrolysis — where the polyester linkage is broken by a reaction with water. One of the by-products of this degradation is organic acids. These organic acids accelerate the rate of hydrolytic decomposition. Furthermore, the acids can attack and degrade the magnetic particles.

The lifetime of a tape is defined as the length of time a tape can be archived until it will fail to perform. Tape failure in terms of a change in tape properties will be a characteristic of the particular system on which the tape is intended for play. An end-of-life criterion is a key property and a value which, if exhibited by the storage medium, would indicate a situation where significant data loss is expected. For example, the degree of hydrolysis of a tape binder system is a critical property that may determine the lifetime of a magnetic tape. Figure 10 shows the life expectancy for a Hi Grade VHS tape assuming that the tape will fail when 12% of the binder polymer has hydrolyzed.

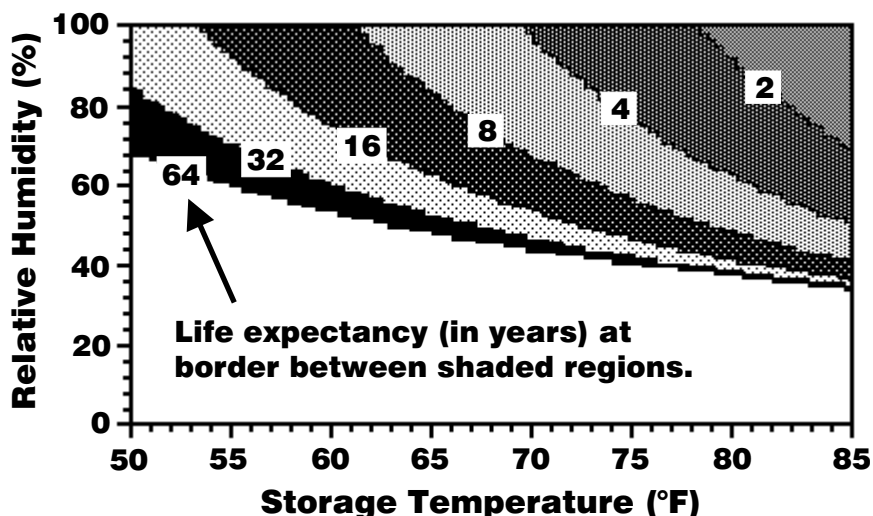

Figure 10. Life Expectancies for a Hi Grade VHS Tape Estimated by the degree of binder hydrolysis using an end-of-life criteria of 12%. LE values are indicated as a function of storage conditions.

Note that from the above chart, humidity is more important in determining the lifetime of the VHS tape than the storage temperature. At 20° C (68° F) and 50% RH, an estimated LE value of ~30 years is indicated. If the storage temperature is raised to 25° C (76° F) at 50% RH, the LE is reduced to ~10 years. However, if the humidity is raised to 80% at 20° C (68° F), the LE is reduced to ~5 years.

The life expectancy chart above was generated solely on the basis of a specific degree of hydrolytic degradation of the binder polymer. Tapes can fail for several reasons, however. Tapes can become too sticky to play as a result of an increase in the coefficient of friction or an overabundance of hydrolysis products. They can fail due to a loss in the magnetic signal as a result of a decrease in magnetic remanence or coercivity. They can fail because the magnetic coating has failed to adhere to the tape backing. They can fail due to irreversible shrinkage of the tape substrate.

The above information was provided to show how estimates of life expectancies can be made. The LE method outlined above is a simple explanation of a much more complicated issue. Standards committees such as the ANSI IT 9-5/AES Joint Technical Commission are endeavoring to determine procedures by which the life expectancy of magnetic tape materials can be determined.

Further Reading

3M Technical Bulletin, 84-9811-2085-4, "Magnetic Tape Recording: Forever?"

3M Technical Bulletin, 84-9811-2075-5, "Temperature and Humidity Recommendation for VTR Facilities."

AMIA Newsletter, The Newsletter of the Association of Moving Image Archivists, c/o National Center for Film and Video Preservation, The American Film Institute, PO Box 27999, 2021 North Western Avenue, Los Angeles, CA 90027.

De Lancie P., "Sticky Shed Syndrome — Tips on Saving Your Damaged Master Tapes," *Mix*, May 1990, p. 148.

Ford, H., "Handling and Storage of Tape," *Studio Sound*, December 1984.

Geller, Sidney B., *Care and Handling of Computer Magnetic Storage Media*, NBS Special Publication 500-101, June 1983.

Jenkinson, B., "Long Term Storage of Videotape," *BKSTS Journal*, March 1982.

Kalil, F., "Care, Handling, and Management of Magnetic Tape," *Magnetic Tape Recording for the Eighties*, NASA Reference Publication 1075, April 1982.

Krones, F., "Guidelines for the Conservation of Magnetic Tape Recordings — Preservation and Restoration of Moving Images and Sound," *International Federation of Film Archives*, 1986.

Reilly, J., "IPI Storage Guide for Acetate Film," *Image Permanence Institute*, 1993.

Ritter, N., "Magnetic Recording Media: Part 1: Care and Handling of Magnetic Tape," 3M Company, 1985.

SMPTE Recommended Practice RP 103, "Care and Handling of Magnetic Recording Tape," 1982.

St.-Laurent, G., "Preservation of Recorded Sound Materials," ARSC Journal (Association for Recorded Sound Collections, PO Box 10162, Silver Spring, MD 20914), V.23, n.2, Fall 1992.

Wheeler, J., "Long-Term Storage of Videotape," SMPTE Journal, June 1983.

Resources for Transfer and Restoration of Video and Audio Tape

These resources were identified by librarians and archivists. Their inclusion does not infer recommendation or endorsement by the National Media Lab or the Commission on Preservation and Access.

Audio

Adrian Cosentini
3422 214th Place
Bayside, NY 11361

Steve Smolian
Smolian Sound Studios
1 Wormans Mill Ct. #4
Frederick, MD 21701

Seth B. Winner
Sound Studios Inc.
1296 East 48th St.
Brooklyn, NY 11234-2102

Video

Grace Lan
Bay Area Video Coalition
1111 17th St.
San Francisco, CA 94107

Jim Lindner
VidiPax
920 Broadway, 16th Floor
New York, NY 10010

Jim Wheeler
Tape Archival & Restoration Service
1736 Valley View
Belmont, CA 94002

Glossary

Access storage: Storage conditions at or near room ambient conditions that allow tape

collections to be readily accessed for immediate playback.

AES: Abbreviation for Audio Engineering Society.

Analog recording: A recording in which continuous magnetic signals are written to the tape that are representations of the voltage signals coming from the recording microphone or the video camera.

Analog-to-digital: The process in which a continuous analog signal is quantized and converted to a series of binary integers.

ANSI: Abbreviation for American National Standards Institute.

Archival storage: Storage conditions specifically designed to extend or maximize the lifetime of stored media. Generally involves the use of temperatures and humidities lower than access storage conditions. Temperatures and humidities are also tightly controlled within a narrow range, and access by personnel is limited.

Backing: See substrate.

Binary number: A number that can be represented using only two numeric symbols – 0 and 1. A number in base 2.

Decimal Number	Binary Equivalent
0	0
1	1
2	10
4	100
12	1100
100	1100100
1995	11111001011

Binary numbers are used by computers because they can easily be represented and stored by device hardware that utilizes switches, magnetic fields, or charge polarities that are normally

in one of two states. The on or off, north or south, or positive or negative states can easily represent the 1s and 0s of a binary number, respectively.

Binder: The polymer used to bind magnetic particles together and adhere them to the tape substrate. Generally, a polyester or polyether polyurethane based system. See polymer.

Bit: A single numeric character. Each bit of a binary number can either be 0 or 1. An n-bit number is composed of exactly n numeric characters. An n-bit binary number can have 2^n distinct values. For example, an 8-bit binary number has $2^8 = 256$ distinct values, namely all the numbers between 00000000 (0 in decimal) and 11111111 (255 in decimal), inclusive. 8-bit quantization would discretely sample a signal and assign each sampling a value between 0 and 255, permitting 256 possible values.

Blocking: The sticking together or adhesion of successive windings in a tape pack. Blocking can result from (1) deterioration of the binder, (2) storage of tape reels at high temperatures, and/or (3) excessive tape pack stresses.

Cinching: The wrinkling, or folding over, of tape on itself in a loose tape pack. Normally occurs when a loose tape pack is stopped suddenly, causing outer tape layers to slip past inner layers, which in turn causes a buckling of tape in the region of slip. Results in large dropouts or high error rates.

Coercivity: The level of demagnetizing force that would need to be applied to a tape or magnetic particle to reduce the remanent magnetization to zero. A demagnetizing field of a level in excess of the coercivity must be applied to a magnetic particle in order to coerce it to change the direction of its magnetization. Coercivity is the property of a tape that indicates its resistance to demagnetization and determines the maximum signal frequency that can be recorded by a tape. H_c is the common abbreviation for coercivity.

Cohesive force: The force that holds a material together. The force that holds a material to itself.

Cohesiveness: See cohesive force.

Curvature error: A change in track shape that results in a bowed or S-shaped track. This becomes a problem if the playback head is not able to follow the track closely enough to capture the information.

dB: See decibel.

Decibel: The unit of measure used to indicate relative changes in signal intensity or sound volume. The actual expression for calculating the difference in decibels between signal A and signal B is:

decibel (dB) = 20 · log_{base 10} (signal A amplitude / signal B amplitude)

+6 dB represents a doubling of the signal or a 100% increase

+5 dB represents a 78% increase

+4 dB represents a 58% increase

+3 dB represents a 41% increase

+2 dB represents a 26% increase

+1 dB represents a 12% increase

+0 dB represents no change-signals are equal

-1 dB represents a 11% decrease

-2 dB represents a 21% decrease

-3 dB represents a 29% decrease

-4 dB represents a 37% decrease

-5 dB represents a 44% decrease

-6 dB represents a halving of the signal or a 50% decrease

Digital recording: A recording in which binary numbers are written to the tape that represent quantized versions of the voltage signals from the recording microphone or the video camera. On playback, the numbers are read and processed by a digital-to-analog converter to produce an analog output signal.

Digital-to-analog: The process in which a series of discrete binary integers is converted to a continuous analog signal.

Dropout: Brief signal loss caused by a tape head clog, defect in the tape, debris, or other feature that causes an increase in the head-to-tape spacing. A dropout can also be caused by missing magnetic material. A video dropout generally appears as a white spot or streak on the video monitor. When several video dropouts occur per

frame, the TV monitor will appear snowy. The frequent appearance of dropouts on playback is an indication that the tape or recorder is contaminated with debris and/or that the tape binder is deteriorating.

Flange pack: A condition where the tape pack is wound up against one of the flanges of the tape reel.

Format: The arrangement of information tracks on a tape as prescribed by a standard. The two most common categories of recording formats are longitudinal and helical scan.

Head clog: Debris trapped in the playback head of a video recorder. Clogging of the playback head with debris causes dropouts.

Helical scan recording: The recording format in which a slow moving tape is helically wrapped 180° around a rapidly rotating drum with a small embedded record head. The tape is positioned at a slight angle to the equatorial plane of the drum. This results in a recording format in which recorded tracks run diagonally across the tape from one edge to the other. Recorded tracks are parallel to each other but are at an angle to the edge of the tape.

Hydrolysis: The chemical process in which scission of a chemical bond occurs via reaction with water. The polyester chemical bonds in tape binder polymers are subject to hydrolysis, producing alcohol and acid end groups. Hydrolysis is a reversible reaction, meaning that the alcohol and acid groups can react with each other to produce a polyester bond and water as a by-product. In practice, however, a severely degraded tape binder layer will never fully reconstruct back to its original integrity when placed in a very low-humidity environment.

Hygroscopic: The tendency of a material to absorb water. An effect related to changes in moisture content or relative humidity. The hygroscopic expansion coefficient of a tape refers to its change in length as it takes up water upon an increase in the ambient relative humidity.

Longitudinal recording: A recording format in which a slow or fast moving tape is passed by a stationary recording head. The recorded tracks are parallel to the edge of the tape and run the full length of the tape.

Lubricant: A component added to the magnetic layer of a tape to decrease the friction between the head and the tape.

Magnetic particles: The magnetic particles incorporated in the binder to form the magnetic layer on a magnetic tape. Iron oxide, chromium dioxide, barium ferrite, and metal particulate are various examples of magnetic pigment used in commercial tapes. The term pigment is a carry over of terminology from paint and coating technology — the magnetic coating on a tape is analogous to a coat of paint in which the magnetic particle is the paint pigment.

Magnetic pigment: See magnetic particles.

Magnetic remanence: The strength of the magnetic field that remains in a tape or magnetic particle after it is (1) exposed to a strong, external magnetic field and (2) the external field is removed. The property of a tape that determines its ability to record and store a magnetic signal. Mr is the common abbreviation for magnetic remanence. Magnetic remanence, Mr, and magnetic retentivity, Br, both refer to the ability of the tape to retain a magnetic field; however the latter is expressed in units of magnetic flux density.

Magnetic retentivity: See magnetic remanence.

Mistracking: The phenomenon that occurs when the path followed by the read head of the recorder does not correspond to the location of the recorded track on the magnetic tape. Mistracking can occur in both longitudinal and helical scan recording systems. The read head must capture a given percentage of the track in order to produce a playback signal. If the head is too far off the track, recorded information will not be played back.

NARA: The abbreviation for National Archives and Records Administration.

Pack slip: A lateral slip of selected tape windings causing high or low spots (when viewed with tape reel laying flat on one side) in an otherwise smooth tape pack.

Pack slip can cause subsequent edge damage when the tape is played, as it will unwind unevenly and may make contact with the tape reel flange.

PET: Abbreviation for polyethylene terephthalate. The polymeric substrate material used for most magnetic tapes.

Polymer: A long organic molecule made up of small, repeating units (literally, many mers). Analogous to a freight train, where each individual unit is represented by a freight car. At very high magnification, a chunk of polymer would resemble a bowl of cooked spaghetti. Plastic materials are polymers. The strength and toughness of plastics is due, in part, to the length of its polymer molecules. If the chains (links in the freight train) are broken by hydrolysis, the shorter chains will impart less strength to the plastic. If enough polymer chains are broken, the plastic will become weak, powdery, or gooey. See binder.

Popped strand: A strand of tape protruding from the edge of a wound tape pack.

Print through: The condition where low frequency signals on one tape winding imprint themselves on the immediately adjacent tape windings. It is most noticeable on audio tapes where a ghost of the recording can be heard slightly before the playback of the actual recording.

Quantization: A process in which a continuous signal is converted to a series of points at discrete levels. The quantized version of a ramp, a continuum of levels, would be a staircase, where only certain distinct levels are allowed.

Refreshing: This term can refer to periodic retensioning of tape, or the rerecording of recorded information onto the same tape (or different tape) to refresh the magnetic signal. In the audio/video tape community, refreshing generally refers to retensioning of the tape, but it can also refer to the copying of one tape to another. See transcription.

Relative humidity (RH): The amount of water in the air relative to the maximum amount of water that the air can hold at a given temperature.

Restoration: The process where a tape degraded by age is temporarily or permanently restored to a playable condition. The tape backing procedure is an example of a tape restoration procedure.

Retensioning: The process where a tape is unspooled onto a take-up reel and then rewound at a controlled tension and speed. In performing this procedure, tape pack stresses are redistributed and, thus, the tape is retensioned. This has sometimes been referred to as refreshing (or exercising the tape).

RH: The abbreviation for relative humidity.

Room ambient conditions: The temperature, humidity, and air quality of the surrounding conditions. Those conditions generally found in a library, resource, studio, or office facility with a controlled environment (heating and air conditioning), which should range between 66 to 78° F (19 To 26° C) and 30 to 70% relative humidity year round. Analogous to room temperature conditions, except that this term only refers to the temperature of the room.

Scission: The process in which a chemical bond in a molecule is broken either by reaction with another molecule, such as water, or by the absorption of a high energy photon.

Signal-to-noise ratio: The ratio of the recorded signal level to the tape noise level normally expressed in decibels. Commonly abbreviated as S/N.

SMPTE: Abbreviation for the Society of Motion Pictures and Television Engineers.

Stick slip: The process in which (1) the tape sticks to the recording head because of high friction; (2) the tape tension builds because the tape is not moving at the head; (3) the tape tension reaches a critical level, causing the tape to release from and briefly slip past the read head at high speed; (4) the tape slows to normal speed and once again sticks to the recording head; (5) this process is repeated indefinitely. Characterized by jittery movement of the tape in the transport and/or audible squealing of the tape.

Sticky shed: The gummy deposits left on tape path guides and heads after a sticky tape has been played. The phenomenon whereby a tape binder has deteriorated to such a degree that it lacks sufficient cohesive strength so that the magnetic coating sheds on playback. The shedding of particles by the tape as a result of binder deterioration that causes dropouts on VHS tapes.

Sticky tape: Tape characterized by a soft, gummy, or tacky tape surface. Tape that has experienced a significant level of hydrolysis so that the magnetic coating is softer than normal. Tape characterized by resinous or oily deposits on the surface of the magnetic tape.

Stress: Force per unit area, such as pounds per square inch (psi). A tape wound on a reel with high tension results in a tape pack with a high interwinding stress. See tension.

Substrate: Backing film layer that supports the magnetic layer in a magnetic tape. PET is currently the most commonly used tape substrate.

Tape baking: A process in which a magnetic tape is placed at an elevated temperature for a brief time in order to firm up the tape binder. This procedure is recommended as a temporary cure for the sticky shed or sticky tape syndrome. The tape baking procedure is discussed in the reference, "Sticky Shed Syndrome — Tips on Saving Your Damaged Master Tapes," Mix, May 1990, p. 148.

Tape noise: A magnetic signal on the tape resulting from the finite size and nonuniform distribution of magnetic particles in the magnetic layer of the tape. Tape noise is inherent in any magnetic tape but can be reduced by using smaller pigment sizes in tape formulations. The iron oxide pigments found in less expensive tapes have the largest tape noise level. Ranked in size: iron oxide > chromium dioxide > metal particulate > barium ferrite. Therefore, ranked in order of tape noise: iron oxide > chromium dioxide > metal particulate > barium ferrite.

Tape pack: The structure formed by and comprised solely of tape wound on a hub or spindle; a tape reel consists of a tape pack, the metal, plastic, or glass hub, and flanges.

Tape transport: The mechanics used to guide and move the tape through the recording system and past the read and write heads of the recorder. The tape transport consists of the tape guide pins, capstan, rollers, tension controllers, etc.

Tension: Force, or force per tape width. The force on a tape as it is transported through a recorder. A tape wound on a reel with high tension results in a tape pack with a high interwinding stress. See stress.

Thermal: An effect related to changes in temperature. The thermal expansion coefficient of a tape refers to its change in length upon a change in the ambient temperature.

Track angle: The angle that the track of a helical scan recording makes to the edge of the tape. This should correspond with the scan angle of the helical recorder — the angle that the tape makes to the equatorial plane of the rotating drum head. If the track angle and scan angle do not correspond, mistracking will occur.

Transcription: The process of copying all of the information on one tape to another tape of the same or different format. The term refreshing is commonly used by some archivists and librarians to refer to the process of copying information from one tape to a newer tape of the same format (e.g., VHS to VHS). When the information is copied to a different format (e.g., BetaMax to VHS), the terms reformatting and converting have been used.

Trapezoidal error: A change in the angle of a recorded helical scan track. Can result in mistracking.

Vinegar syndrome: Characteristic of the decomposition of acetate based magnetic tape where acetic acid is a substantial by-product that gives the tape a vinegar-like odor. After the onset of the vinegar syndrome, acetate tape backings degrade at an accelerated rate — the hydrolysis of the acetate is catalyzed further by the presence of acetic acid by product.